

Reader Interface-Modul for XMP-K32 / K32lite

Applications

- Access control
- Time and attendance

Functions

The **XMP-RIM** provides a local interface between access controller and up to 2 cardreaders for a single door (depending on type of RIM-module).

The RIM-module sends the access card data and the door's position to the access controller. The access controller checks the validity of the cardholder and if the appropriate permissions have been assigned, the access controller sends a message back to the RIM-module allowing to unlock the door and provide passage.

All inputs of the RIM-module can be configured as supervised inputs, wire tampering is reported to the system by generating an alarm message when detected.

Technical data

Power supply RIM-module:	12V / 24V DC ± 10%
Current consumption:	Max. 3 VA without peripheral devices
LED's:	1x Power supply 2x Communication 4x outputs (RIM-002, RIM-004) 2x outputs (RIM-001, RIM-003)
Inputs:	4x supervised inputs on,off, short and broken (0..3)
Outputs:	4x binary output (RIM-001, RIM-003 : 2x)
Output achievement (voltage affected)	max. 12 V DC / 250mA each output max. 24V DC / 125mA each output
Output achievement (potential free)	max. 30 V DC / 2 A
Interface: (Access controller)	RS485-2-wire-interface (9600, 19200 baud)
Interface: (Cardreader)	RIM-001, RIM-002 : RS485-2-wire-interface (9600, 19200 baud) RIM-003 : 1x Wiegand (26bit,32bit) RIM-004 : 2x Wiegand (26bit,32bit)
Fuses:	F3,Relais : T1.0A F1,F2,cardreader : T500mA
Cardreaders:	All K32/K32lite supported cardreaders
Environmental conditions:	Operation: 0..50 °C Storage: -40..70 °C 5 - 95% relative humidity
Dimensions:	(WxDxH) 97 x 97 x 25 mm without housing

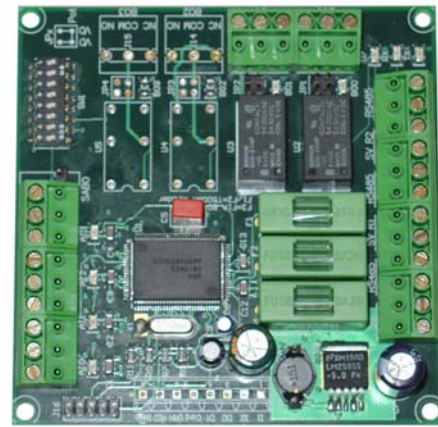

XMP-RIM-Module

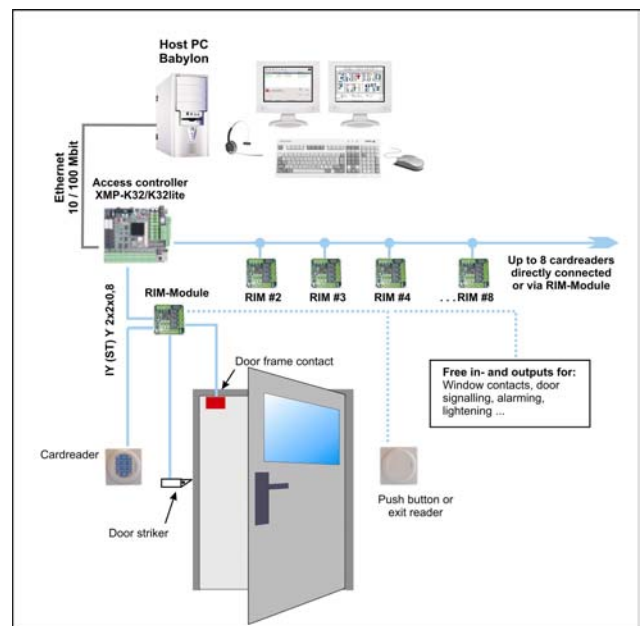

Connection scheme of XMP-RIM-modules to XMP-K32/K32lite





Legend:

XMP-K32lite: Intelligent door controller with 10/100Mbit LAN interface. 100MHz 32 bit cpu with Linux embedded operating system. **25.000** access profiles, **15.000** master data (extendable to **50.000**), **60.000** bookings.

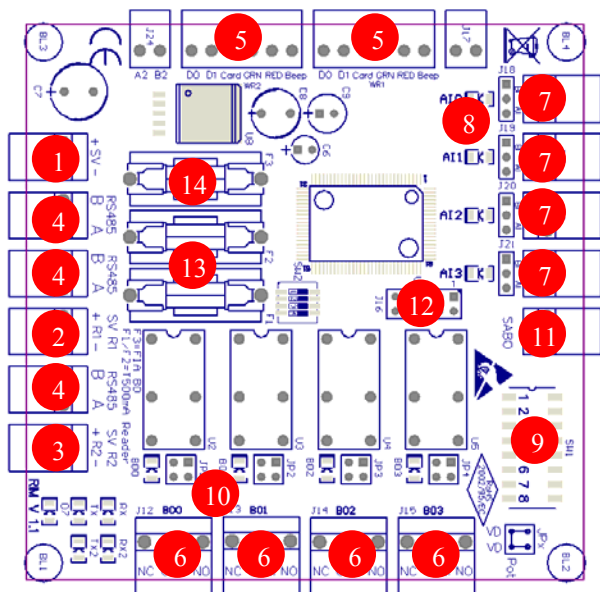
XMP-K32: Intelligent door controller with 10/100Mbit LAN interface. 266MHz 32 bit cpu with Linux embedded operating system. **100.000** access profiles, **500.000** master data (extendable to **2.000.000**), **500.000** bookings.

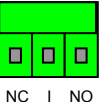
Scheme of the XMP-RIM-Board



1. SV:	Power supply RIM module (12V/24V DC)
2. SV R1:	Power supply cardreader 1 (12V/24V DC)
3. SV R2:	Power supply cardreader 2 (12V/24V DC)
4. RS485:	Connector partyline (1x access controller, 2 x cardreader)
5. J22, J23	Wiegand interface for cardreaders
6. BO0..BO3	Binary outputs (Relais)  (NC = normally closed) (NO = normally open)
7. AI0..AI3	Supervised inputs
8. J19..J21	AI configuration  analogue  binary
9. SW1	Adress-Dipswitch (0-7)
10. JP1..JP4:	BO configuration jumper  VD  p (12V , 24V) (potential free)
11. SABO:	Connector for external tamper
12. J16:	Programming interface <i>Risk of damage, use only as mentioned !</i>
13. F1, F2:	Fuses for cardreaders (T500mA) (Reader 1 = F2 , Reader 2 = F1)
14. F3:	Fuse for outputs (T1.0A)

1. Programming and firmware download

RIM-Modules can be ordered for different applications. Depending on ordering information RIM-Modules are delivered with special software settings. Changes of some factory settings and software update can be done by an K32-utility program W3RIMP.exe.

2. Software

RIM-Modules recommend following software revisions :

- K32/K32lite : V. 3.1 (BD 08.03.07)
- W3K32P : V. 2.7 (BD 07.03.07)
- W3RIMP : V.1.0

3. RIM Module wiring

A) Access controller

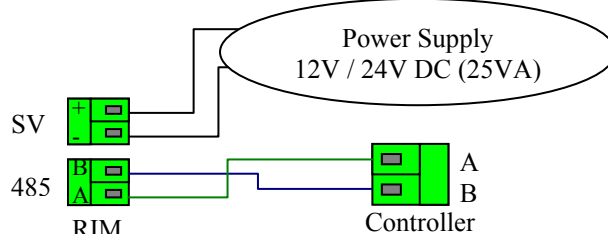

B) Cardreader (RS485)

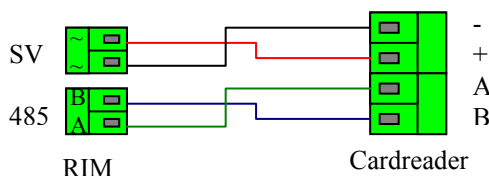

C) Wiegand interface

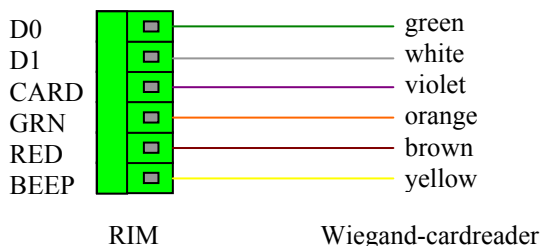

4. Binary outputs (BO)

A) Configuration Voltage affected

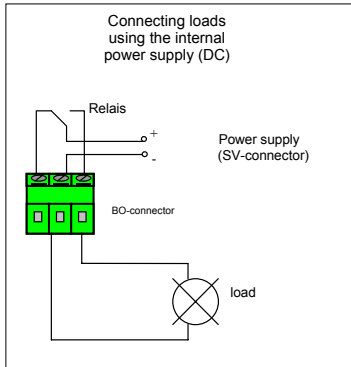

B) Configuration voltage free

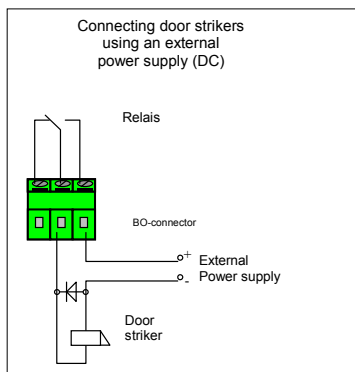

5. Analogue Inputs

A) Configuration 2 values (binary)

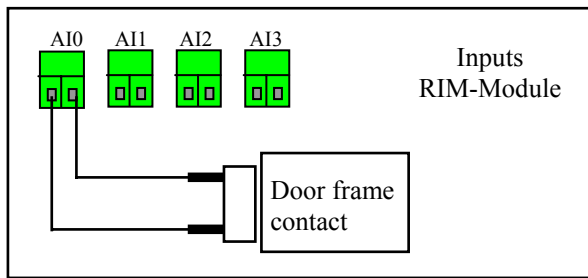

B) Configuration 4 values (analogue)

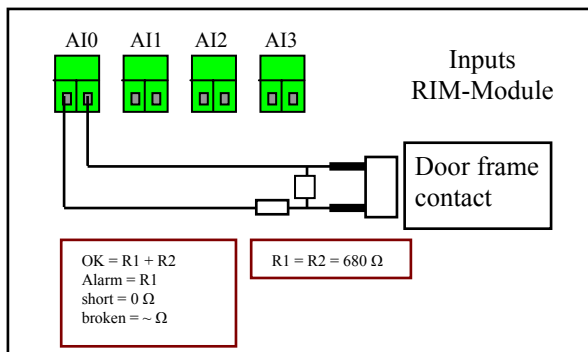

6. Order numbers

XMP-RIM-001	single reader board
XMP-RIM-002	double reader board
XMP-RIM-003	single reader board (wiegand)
XMP-RIM-004	double reader board (wiegand)
XMP-RIM-010	RIM-001 with backplate
XMP-RIM-020	RIM-002 with backplate
XMP-RIM-030	RIM-003 with backplate
XMP-RIM-040	RIM-004 with backplate
XMP-RIM-011	RIM-001 with housing
XMP-RIM-021	RIM-002 with housing
XMP-RIM-031	RIM-003 with housing
XMP-RIM-041	RIM-004 with housing
XMP-RIM-012	RIM-001 with 12V 7Ah UPS
XMP-RIM-022	RIM-002 with 12V 7Ah UPS
XMP-RIM-032	RIM-003 with 12V 7Ah UPS
XMP-RIM-042	RIM-004 with 12V 7Ah UPS
XMP-RIM-013	RIM-001 with 24V 2,9Ah UPS
XMP-RIM-023	RIM-002 with 24V 2,9Ah UPS
XMP-RIM-033	RIM-003 with 24V 2,9Ah UPS
XMP-RIM-043	RIM-004 with 24V 2,9Ah UPS
XMP-RIM-100	Backplate for RIM-Module
XMP-RIM-101	Housing for RIM Module
XMP-RIM-102	12V 7Ah UPS for RIM Module
XMP-RIM-103	24V 2,9Ah UPS for RIM Module
XMP-RIM-110	Din rail mounting set

7. Dimensions (mm)

