

# Terminal XMP-TMC2803-FP

security, time and attendance

## Purpose

The TMC2800 series readers convince because of its user friendly and easy handling. The beautiful, small and ergonomic designed housing fits excellent in every kind of building architecture.

The terminals TMC2800 are designed to connect to a door controller unit XMP-K32lite or XMP-K32.

The readers connection to the door controller is a four-core wire, whereby one double-core provides the power supply and the other is used for data transfer.

## Technical data

<b>Fingerprint sensor:</b>	Optical fingerprint sensor
<b>Display:</b>	Fluorescence display 2x20 digits
<b>Keypad:</b>	5 standard function keys 4 special functional keys (each 8 levels) PIN-Code keyboard
<b>Reader address:</b>	Adjustable by micro switch
<b>Tamper</b>	Internal sabotage contact (reader stops working at sabotage)
<b>Protection type:</b>	IP 65
<b>Power supply:</b>	11-24 V (AC / DC) 5,5-8 VA
<b>Interfaces:</b>	2x RS 485 (2 wire) 9600-19200 Baud asynchronous (1x door controller, 1x reader head)
<b>Processor:</b>	M16C 16 Bit; 16 MHz; CMOS-Design
<b>Memory:</b>	32kB Flash Memory
<b>Case:</b>	Material ABS (impact proofed housing)
<b>Color :</b>	Silver
<b>Protection class:</b>	IP 65
<b>Dimensions (LxWxH):</b>	195 x 130 x 80 mm
<b>Weight:</b>	Approx. 0,62 kg
<b>Environmental conditions:</b>	From -20°C to +70°C (operation and storage) int. heating possible



XMP-TMC2803-FP

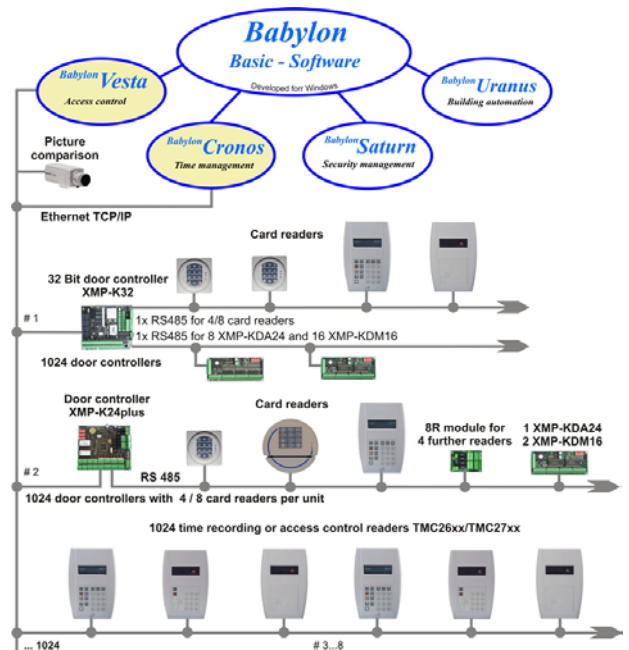

Scheme for the connection possibilities of card readers to BABYLON

## Legend

### Access controller K24Plus, K32Lite, K32:

Door controller unit with RS485 interface. Each XMP-K32-000 and XMP-K32-050 it is possible to connect 8 access and time recording terminals.

### Order No.:

#### XMP-TMC2803- HIT/MIF/LEG

Time and attendance terminal with keyboard, display, fingerprint sensor and reader head

## Possible protocols

BPA/9plus (K32/K32Lite firmware V3.4, BD 07/07/08 and K24plus), and SecuCrypt (K32/K32Lite firmware V3.4, BD 07/07/08)

## Booking times with fingerprint

2 sec. plus response time of K32/K32L (see K32/K32Lite documentation). Up to 100.000 fingerprints per K32/K32Lite.

## Highlights:

- **Status display** with fluorescence display 2x20 digits for the situation of the door opening relay and reader communication.
- **End resistance** for low interrupted data transmission, integrated in the reader and individual configuration possible.
- **Reader addresses** adjustable by dip-switch. All switches can be changed while reader is running.
- **Firmware update** from Host. (using SecuCrypt protocol)
- **Integrated Sabotage tamper** reader stops working at sabotage.
- **Protocol encryption** selectable by micro switch. (BPA/9 plus, plain / SecuCrypt 192 blowfish encrypted)
- **Correction button** also supported during the PIN code input.
- **Supports ASCII badge numbers**
- **High quality encrypted communication** between card reader and door controller. (SecuCrypt )
- **Sunlight protected** build in fingerprint sensor
- **Maintenance free** capacitive sensor keypad
- **Impact proved housing**
- **Indoor / Outdoor** sensor calibration
- **Access on card AOC**
- **Fingerprint on card FOC**
- **FAR: False Acceptance Rate:**  
< 0.0001%
- **FRR: False Rejection Rate:**  
< 0.1%

## Fields of application

Access control  
Time recording  
Time and attendance  
Door management  
Parking Systems  
Elevator control

## The fingerprint option is also available in connection with terminal types:

XMP-TMC2801-FP-MIF/LEG/HIT  
XMP-TMC2802-FP-MIF/LEG/HIT

## Mounting instructions

The XMP-TMC-2803 reader is designed to be wall mounted to internal walls. The wall must have sufficient load-bearing capacity.

### **Suitable wall structures are as follows:**

Concrete walls  
Plastered brick walls  
Plasterboard walls  
(use special attachment systems)  
Ensure that the area is dry,  
clear of dust and, where  
applicable, sufficient accessible.

## Wiring to the door controller

For the installation of an XMP-TMC2802 reader to a door controller, please refer also to the instruction manual

### **Part. No. : IMXMP-K32lite/K32**

delivered with the required door controller XMP-K32 or XMP-K32lite.

Door messages and the activation of the door opener should not pass through a bus cable.

Depending on the door monitoring model, this requires cables with 4 or 5 (6) pairs of wires from door controller to the controlled door.

## Setting the readers parameters

The user has the option of significantly influencing the control behavior of the XMP-TMC2802 reader. Please refer also to the instruction manual

### **Part. No.: UMXMP-K32lite/K32**

delivered with the required door controller XMP-K32 or XMP-K32lite.

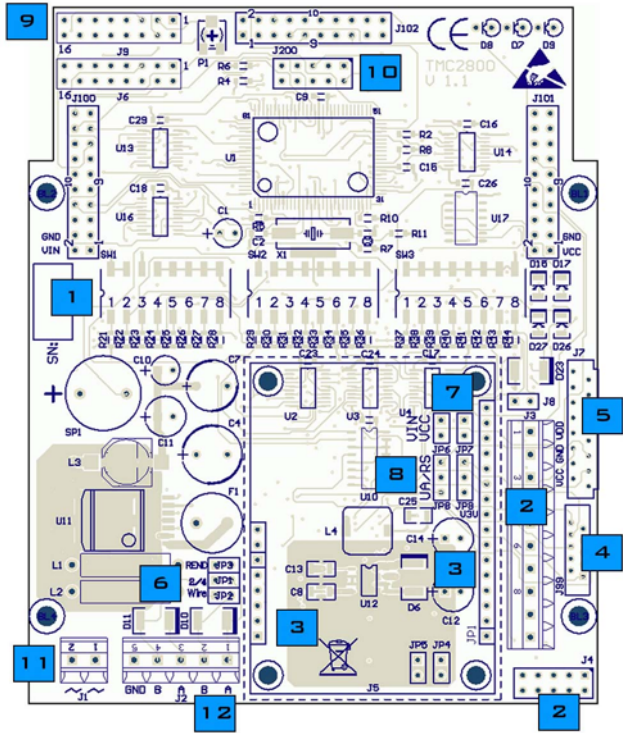

1. Dipswitch block SW1 to SW3
2. Interface reader head
3. Interface for fingerprint sensor
4. Connection to standard keyboard
5. Connection to sensor keyboard / reader head
6. Jumper block JP1 to JP3
  - 2/4 Wire = reader interface (open = 4 wire)
  - 2/4 Wire = reader interface (close = 2 wire)
  - 2/4 Wire = reader interface (open = 4 wire)
  - 2/4 Wire = reader interface (close = 2 wire)
  - REND = reader interface end resistance
7. Power supply 12-24V DC for reader head
8. Interface for reader head (2) UART / RS485
9. Connection to Fluorescent Display
10. Interface for flashing firmware
11. Power supply 12-24V AC/DC
12. RS485 interface (door controller)

**Scheme for the connection of the reader to the XMP-K32 / XMP-K32lite**

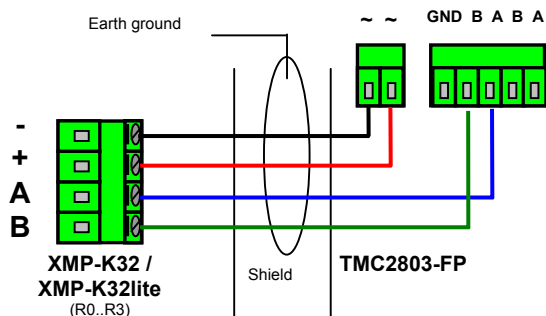

**Dipswitch blocks SW1 to SW3**

**1. Adjusting the reader address**

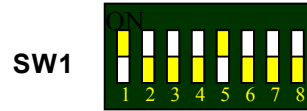

SW1 : switch 1 to 3

Switcher	1	2	3
Address 0	off	off	off
Address 1	on	off	off
Address 7	on	on	on

Addresses adjustable from 0 up to 7

SW1 : switch 5  
protocol type:  
ON = SecuCrypt, OFF = BPA9 plus

SW1 : switch 6  
ON = Sensor keypad

SW1 : switch 7  
OFF = Deister readerhead  
ON = Barcode reader

SW1 : switch 8  
ON = Boot loader activated

**2. Special functions switch block SW 2**

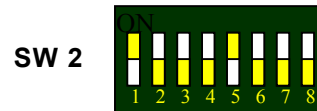

SW2 : switch 1  
Fingerprint On Card activated

SW2 : switch 6  
Adjusting the Baud rate between door controller and reader using the RS485 Bus (9600 = off and 19200 = on).

**3. Switch block SW 3**

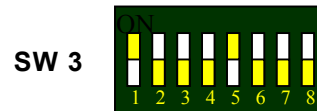

SW3 : switch 3 and 4  
ON = Identification only by fingerprint sensor.  
OFF = Verification (fingerprint and badge/Pin)

SW3 : switch 6  
ON = 8 Bit protocol, when using BPA9 plus.  
OFF = 7 Bit protocol, when using BPA9 plus.

**Add on instruction for the TMC2800 heater**

For additional heating the following parts are needed:

- XMP-TMC2500-NT-12V-BG (Order - NR.)
- XMP-TMC2500-HZ (Order - NR.)

The heater metal can be put on the power pack housing (see picture).

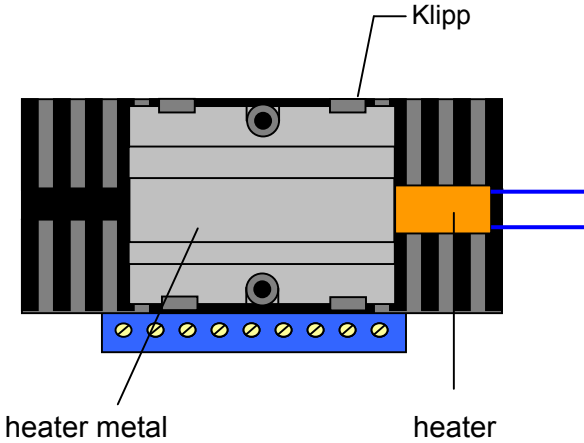

**1. Input:**

AC = 85 Volt – 264 Volt (50Hz)  
 DC = 110 Volt – 370 Volt (Polarity any way)

At the connections plus and minus an output voltage is spent by 12V/0,9A (peak 1,08A, ca. 12 Watt).

The power input is depending upon outside temperature between 300 mA (3.6 Watts) and 500 mA (6 Watt).

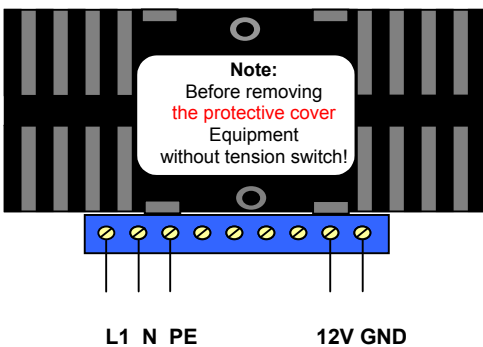

At the ports L, N and PE the mains voltage is attached. Please only of an authorized specialist to accomplish leave.

**2. Technical data**

TMC2500-NT-12V-BG

- 10.8 Watts
- 12 V
- 0.9 ampere
- VDE - Permissions: UL1950, C-UL, EN60950, VDE0160 according to DEN-AN and IEC60950

**3. Effective range of contact less read heads**

The reader head is placed with in the characterized position under the TMC2802-FP - reader front. Within position badges have maximum read distance.



This symbol marks proximity reader head.

**Important customer information!**

Defective circuit boards must be disposed professionally. Batteries and accumulators must be disposed as hazardous waste. The package can be used again or must be disposed. The green filling material can be disposed as bio waste.

