

Dialogue station XMP-DS32

Fields of application

- visualisation and operation of security and building automation systems – **independent** on the management system BABYLON/NT
- realtime display of alarms, process data and dynamic colour graphics
- multiple visualisation functions for building automation, security management and access control



XMP-DS32-000

Special features

- 15" TFT-LCD graphic screen (1024x768 pixels)
- 8 colour graphics with up to 128 dynamic elements per graphic
- supervision and controlling functions for up to 16 K24^{plus}-security, K32 or GA-BOX
- activating and deactivating of alarm groups with selective switch-off function of defective signalling units
- alarmhandling and acknowledgement
- foil keyboard with function keys
- user log-in via password or cardreader
- up to 100 operators with individual configurable authorisations can be involved
- 64 time schedules
- 32 routines (user programs)
- 16 graphical ViPS programs
- build-in UPS (for bridging of short power failures, for approximately 10 min)
- realtime LINUX operating system
- two digital relay outputs (potentialfree/ 12V/ 27V, max. 5A)
- four digital inputs, galvanic separated
- connection possibility of function modules/ cardreaders to a RS485 two wire interface

Technical data

Housing:	stainless steel housing
Colour :	silver-grey
Dimensions (WxHxD):	470 x 270 x 85 mm
Protection type:	IP 55
Voltage supply:	27,6 V DC (external)
Power consumption:	approx. 75 VA
Environmental conditions:	operation: 0°C bis 50°C storage: -40°C bis +70°C 5 - 95% relative humidity
Interfaces:	RS 485 (2 wire) 10/100Mbit LAN
Processor:	266 MHz AMD Geode GX1 32 bit processor (Intel Pentium compatible)
Program memory:	128 MB Compact-Flash-Card
RAM:	128 MB RAM

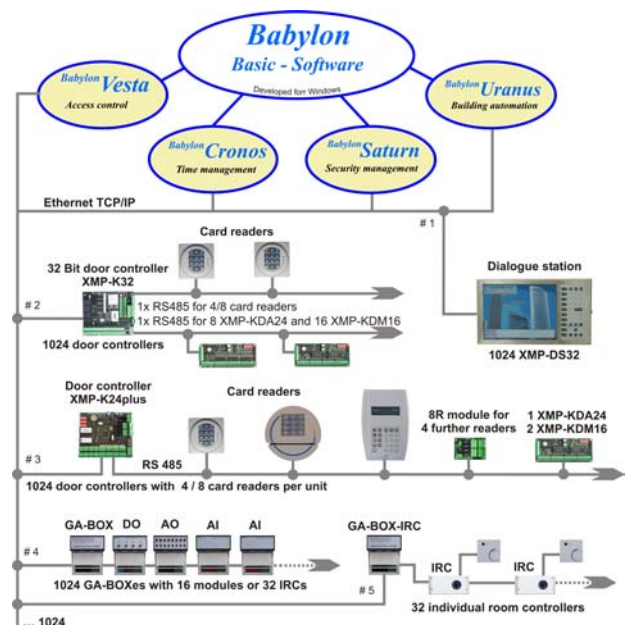

Scheme for the connection of the dialogue station XMP-DS32 to BABYLON/NT

Legend

XMP-K24^{plus}: Intelligent door control unit for the connection of up to 4 (max. 8) access terminals. It is equipped with 8 binary outputs and 16 binary inputs for the door control but also useful for other controlling tasks.

XMP-K32: Intelligent door control unit with 10/100 Mbit LAN interface. 266MHz 32 bit processor with Linux embedded operating system. **100.000** access profiles, **500.000** master data (extendable on **2.000.000**), **500.000** bookings.

XMP-GA-Box: Controlling and communication module for building automation with 10Mbit LAN interface. Up to 16 XMP-GA modules (binary/analogous in- and outputs) with their corresponding datapoints can be connected on it. As **XMP-GA-BOX-IRC** the module controls up to 32 individual room controllers (XMP-IRC).

Order number: XMP-DS32-000

XMP-DS32 board – schematic representation

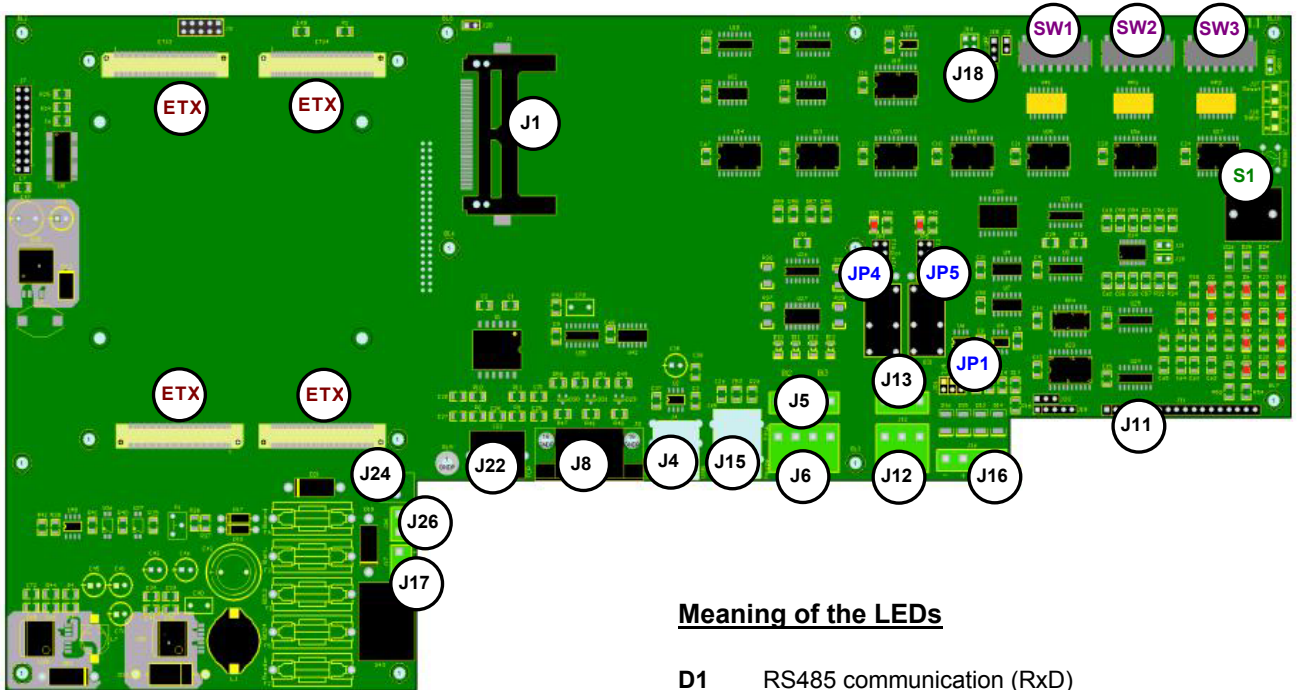

- J1** socket for CF card
- J4** USB connection (not active at the moment)
- J5/J6** 4 binary inputs BI
- J8** VGA connection (option)
- J11** connector for DS32 foil keyboard
- J12/J13** binary outputs BO (potentialfree/12V/27V → can be set with the jumpers JP4/JP5)
- J15** above – keyboard connection PS2 (option)
below – mouse connection PS2 (option)
- J16** serial interface (RS485)
- J17** connection for ext. voltage supply 27,6 V DC
- J18** buffer battery for realtime clock
- J22** Ethernet connector (RJ45)
- J24** battery connection
- J26** connector for LCD inverter (pre-wired)
- JP1** RS485 connection (2 wire/ 4 wire/ termination resistor)
- JP4/JP5** configuration of the BO output potentials (J12/J13)
- S1** Reset push button for controlled “driving-down” of the DS32
- ETX1..**
ETX4 sockets for the ETE module
- SW1..**
SW3 micro switch blocks

Meaning of the LEDs

- D1** RS485 communication (RxD)
- D2** RS485 communication (TxD)
- D4** Ethernet communication (traffic)
- D5** Network connection (phys.) RJ45 plugged in
- D6** 10 MBit operation (off)
100 MBit operation (on)
- D7** DS32 operation LED
- D10** Reset activated

Micro switch blocks 1..3

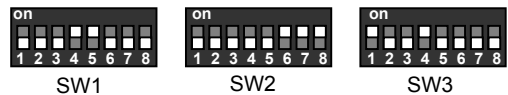

SW1 switch 1..8	For binary setting of the DS-32 hardware address (0..1023)
SW2 switch 1..2	
3	reserved
4	reserved
5	reserved
6	http server activated
7	FTP server activated
8	software activated (always On)
SW3 switch	
1	Baud rate für reader port (0=4800, 1=9600, 2=19200, 3=38400 baud)
2	
3	reserved
4	reserved
5	reserved
6	reserved
7	telegram coding on/off
8	on=cold start

RS485 configuration JP1

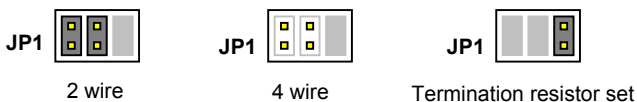

Configuration of the BO output potentials JP4/JP5

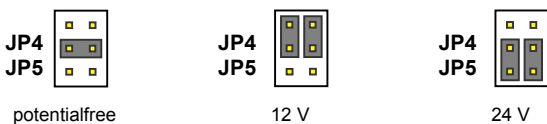

JP4 is assigned to BO0(J12) and JP5 to BO1 (J13).

