

TMC2230 HITAG® cardreader

Applications

- Access control
- Time recording
- Time and attendance
- Door management
- Parking systems
- Elevator control

Functions

- contactless reading method (MIRO / HITAG-1® / HITAG-2® read only)
- reading distance: from 7 to 10 cm
- connection of 8 cardreaders to the access controller **XMP-K24^{plus}** or **XMP-K32**
- firmware update from Host-PC
- adjustable address via dip switch
- sabotage tamper
- optionally with PIN-CODE keyboard (XMP-TMC2240)
- easy mounting by Phoenix connectors
- signalling: 3 x LED`s, 1 x buzzer
- impact proofed housing (ABS)

Technical data

Housing:	ABS
Color :	Similar RAL9006/9007 silver
Dimensions (HxLxW):	50 x 136 x 25 mm
Protection:	IP 54
Power supply:	12-24 V (AC / DC)
Current consumption:	app.120mA at 12V DC
Environmental conditons:	-20°C to +70°C (operation and storage)
Interface:	RS 485 (2 wire)
Processor:	M16C 16 Bit; 16 MHz; CMOS-Design
Memory:	RAM 20kB Flash-Memory 256kB
Accessories:	Individual painting, High protection (IP65)

Important customer information!

Defective circuit boards must be disposed in competent manner. Old batteries and accumulators are hazardous waste. The package can be used again or can be disposed. The green filling material can be disposed as bio waste.



XMP-TMC2230

XMP-TMC2240

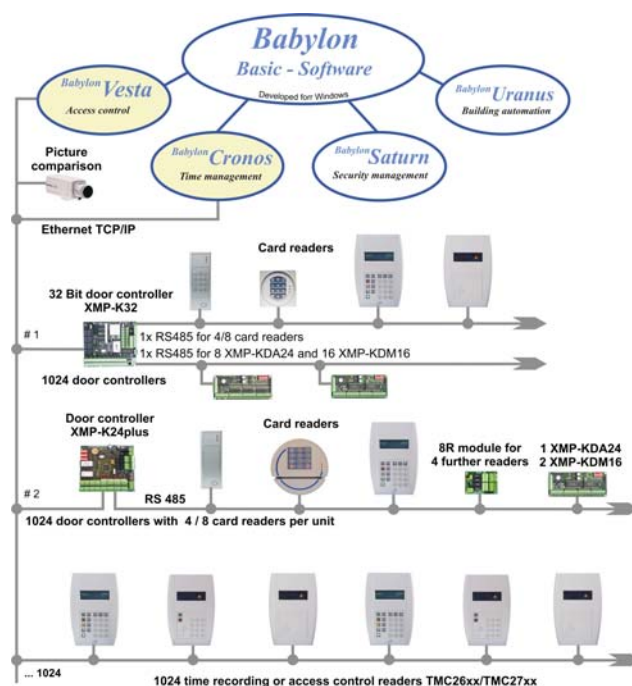

Scheme for the connection possibilities of cardreaders to BABYLON/NT

Legend

XMP-K24^{plus}: Intelligent door control unit with RS485 and 10Mbit LAN interface. Up to 8 access control terminals are connectable. The **XMP-K24^{plus}** is equipped with 8 digital outputs and 16 digital inputs.

XMP-K32: Intelligent door control unit with RS485- and 10/100Mbit LAN interface. It is equipped with a 266MHz processor (embedded Linux operating system). **100.000** access profiles, **500.000** badges (extendable on **2.000.000**), **500.000** bookings.

Order-Numbers:

XMP-TMC2230 card reader

XMP-TMC2240 card reader with PIN-Code

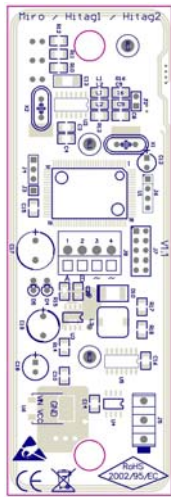

Backside of the cardreader

Terminal assignment for the XMP-TMC2230/2240

TMC2230 TMC2240 (J1)	XMP-K24/K32 (R1..R4)	Description
~	+ or -	Power supply
~	+ or -	Power supply
B	B	RS485 Reader Interface
A	A	RS485 Reader Interface

Connection sheme for electrical wiring of XMP-TMC2230/2240 cardreaders and access controllers XMP-K24^{plus} or XMP-K32

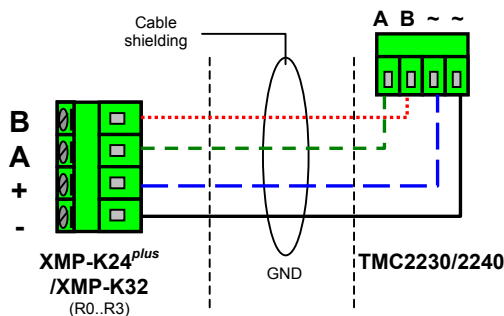

Hints on wiring:

The card reader can be powered from access controllers internal power supply (12 VDC or 24VDC). The RS485 communication interface can be wired via bus or star structure.

Card reader distances and cable types:

Distance	Type of cable
Up to 200 m	2x2x0,8 (shielded)

Meaning of the micro switches SW1

Switch	Meaning
1-3	For binary setting of the reader addresses 0..7 (e.g. only switch 1 = ON → reader address 1, or only switch 3 = ON → reader address 4, or 1, 2 and 3 = ON → reader address 7)
4	Default OFF
5	Baudrate setting to K24/K32 OFF: 9600 (suggested); ON = 19200
6	ON = UCI-Protokoll
7	Reserved
8	ON = Bootloader activated

Hints to the reading methods

The TMC2430/2440 reads the **serial number** of Miro-, Hitag-1 and Hitag-2 badges. The reader transmits a 14 digit badge information. Digit 14 of the read badgetype represents: 0 = Miro, 1 = Hitag-1, 2 = Hitag-2. In case of evaluating a 14 digit badge information it can be necessary to replace digit 14 by a blank in the **K24/K32 parameters**, e.g., if different reader types are in use.

Hints for reading distance

In dependence on the environment conditions and types of data carrier the reading distance is between 50 and 80 mm. Metal parts within the distance of 120 mm to the reader can reduce the reading distance. Recommended badge types: ISO standard

Meaning of the LEDs

- yellow: operation state
- red: not authorized
- green: authorized
- Backside D4: communication TXD
- Backside D5: communication RXD

Reader protocol

UCI - Omron 5 Bit (like magnetic stripe)
(Hint: XMP-K24^{plus} – firmware release 3.8 or higher needed)
SecuCrypt® - Blowfish encryption
(Hint: only for XMP-K32/K32lite)

Dimensions (mm)

